

WCM 21VF

Weather Proof IR CAMERA



Features

- 1/3 inch Sony Super HAD CCD
- High Resolution : 600 TV Lines
- Built-in Vari-focal Lens (f=3.8~9.5mm)
- Smart IR Technology
- Built-in IR LED(18EA)
- TDN(ICR)
- Min Illumination : Night(0.00Lux, IR LED On)
- Auto White Balance
- Weather Proof Housing
- 65mm in Diameter
- 12VDC
- IP66

DIMENSIONS

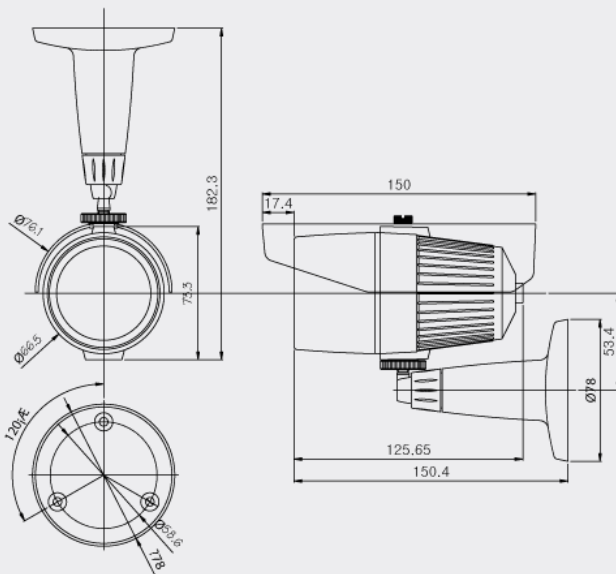

SPECIFICATIONS

Model	WCM 21VF
Signal System	PAL
Scanning System	2:1 Interlace
Scanning Frequency (H)	15.625 KHz
Scanning Frequency (V)	50 Hz
Image Sensor	1/3 Inch SONY Super HAD CCD
Total Pixels	795(H) x 596(V) 470K
Effective Pixels	752(H) x 582(V) 440K
Horizontal Resolution	600 TV Lines (BW 650TV Lines)
Video Output	1.0V p-p (75 Ω, Composite)
S/N Ratio	More than 50dB(AGC Off)
Lens	Vari-focal Lens (f=3.8~9.5mm)
Min.Illumination	0.1 Lux (Color), 0.01 Lux (B/W), 0.00 Lux (IR LED On)
IR LED and Sensor	Smart IR Technology, IR LED 18EA (850nm, 30 °)
IR LED Visible Range	Max. 20m
Day&Night (ICR)	Auto
Digital Noise Reduction	Low, Middle, High, Off
White Balance	Auto
AGC	On/Off (Dip Switch)
Shutter Speed	1/50~1/120,000sec.
Supplied Voltage	12VDC
Power Consumption	Max. 6W/0.5A
Dimensions(ØxH)	78.0 x 150.0mm
Weight	Approx. 800g